

UCHIDA

操 作 手 冊

Paper Folder EZF-500



1-1 外觀

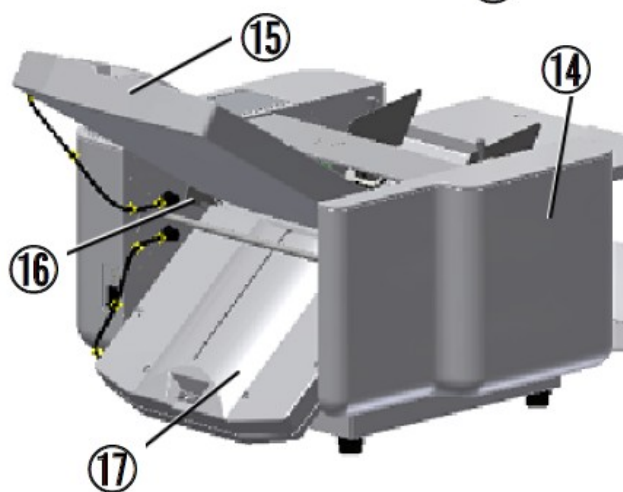
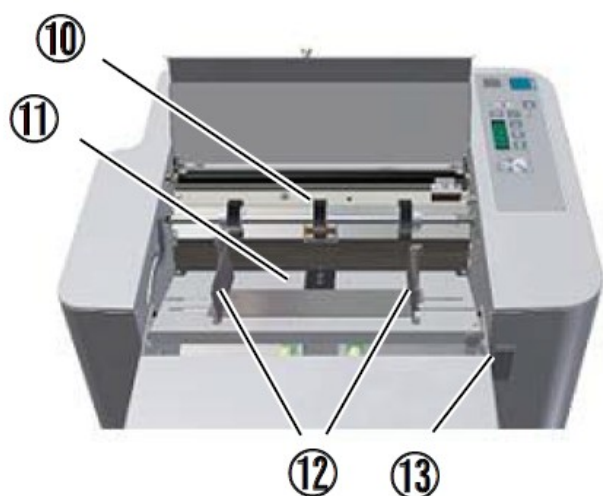
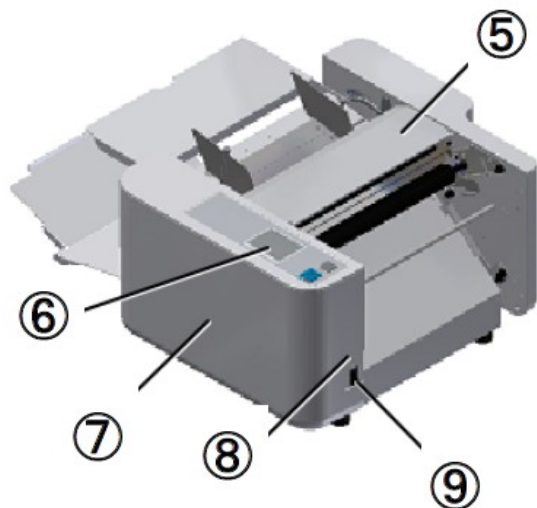
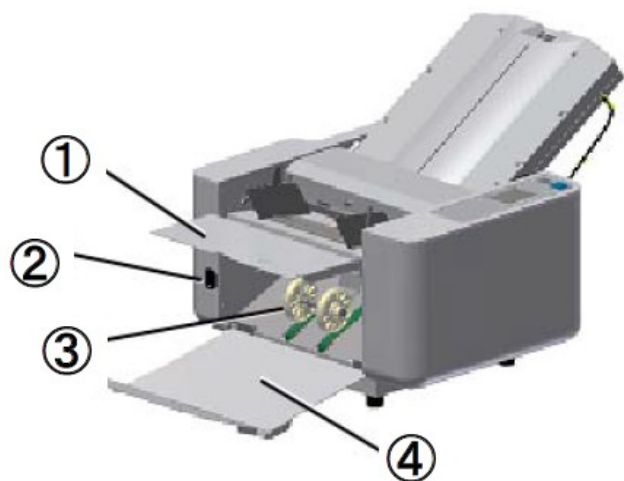

號碼	名稱	號碼	名稱
1	延伸板	11	載紙台
2	電源接頭	12	置中擋規
3	出紙輔助輪	13	載紙台升降
4	出紙台	14	左側蓋
5	上安全蓋	15	上折盤
6	控制面板	16	滾輪調整器
7	右側蓋	17	下折盤
8	保險絲		
9	電源開關		
10	進紙輪		

1-2 控制面板

編號	名稱
A	LCD 觸控面板
B	“測試”鍵
C	“開始/停止”鍵

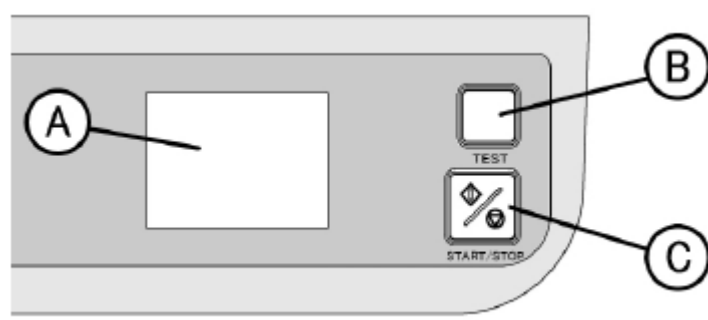

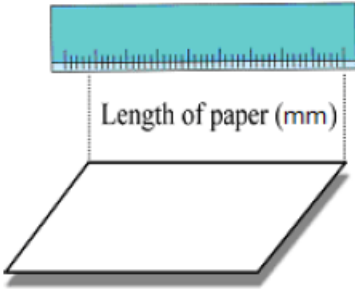
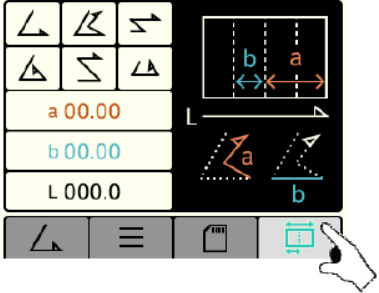
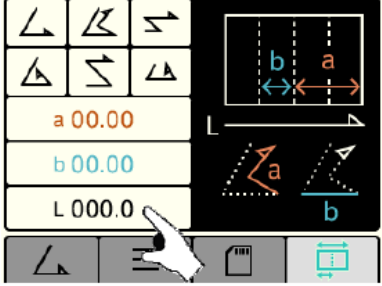
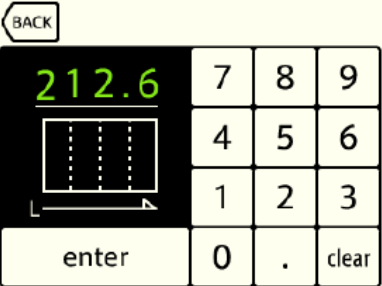
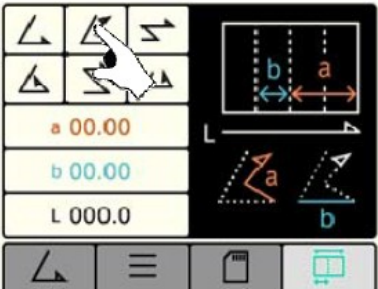
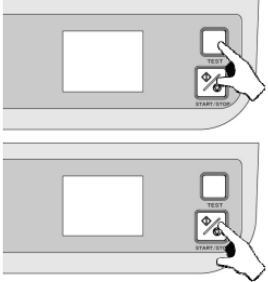

2-1 手動輸入紙張尺寸

	
<p>[1] 測量紙張長度</p>	<p>[2] 按“不規則折型”鍵</p>
	
<p>[3] 按 L(黑色數值)鍵</p>	<p>[4] 輸入紙張長度</p>
	
<p>[5] 選擇折型</p>	<p>[6] 按“測試”鈕，如結果不正確，請確認輸入是否正確</p>

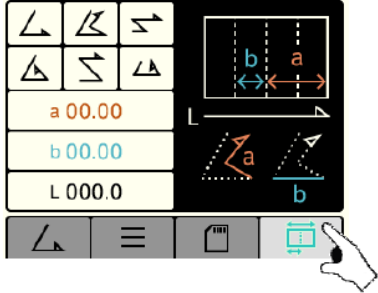
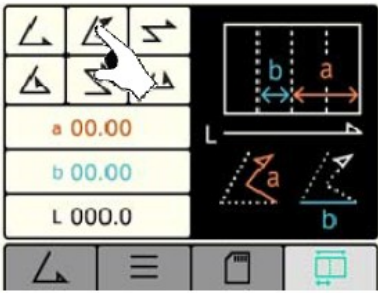
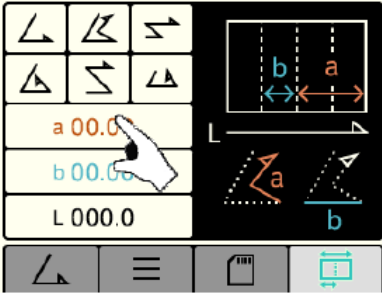
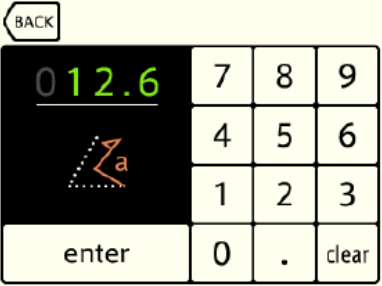
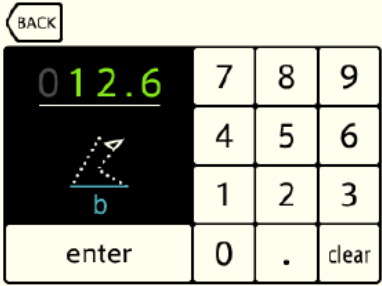
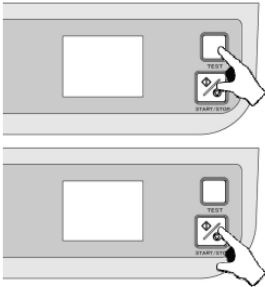
2-2 不規則折型輸入

	
<p>[1]按“不規則折型”鍵</p>	<p>[2]選擇折型</p>
	
<p>[3]按 a(紅色數值)及 b(藍色數值)鍵</p>	<p>[4]輸入 a(紅色數值)長度</p>
	
<p>[5]輸入 b(藍色數值)長度</p>	<p>[6]按“測試”鈕，如結果不正確，請確認輸入是否正確</p>

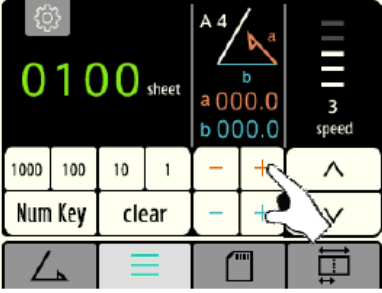
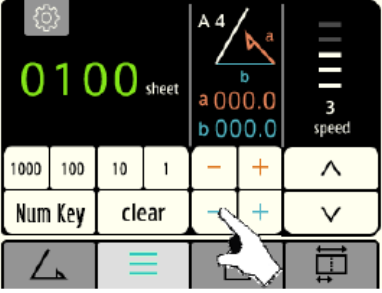
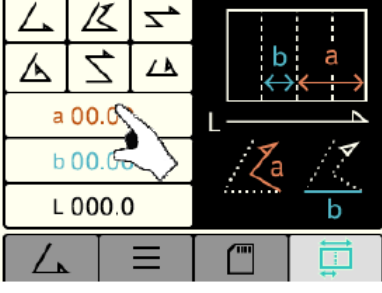
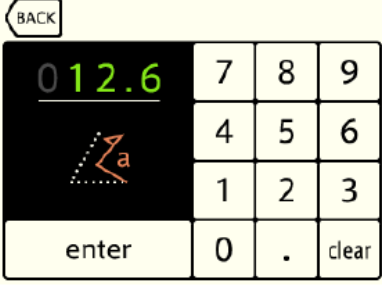
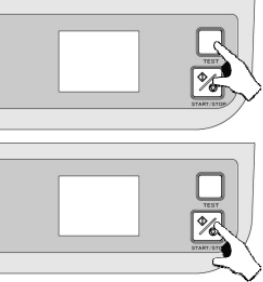
2-3 細微調整尺寸

	
<p>[1]按紅色“+”或“-”鍵來調整 a 尺寸</p>	<p>[2] 按藍色“+”或“-”鍵來調整 b 尺寸</p>
	
<p>[3]按 a(紅色數值)及 b(藍色數值)鍵</p>	<p>[4]輸入 a(紅色數值)長度</p>
	
<p>[5]按“測試”鈕，如結果不正確，請確認輸入是否正確</p>	<p>※※或是直接調整“手動微調旋轉鈕” ※※</p>

3-1 儲存記憶功能

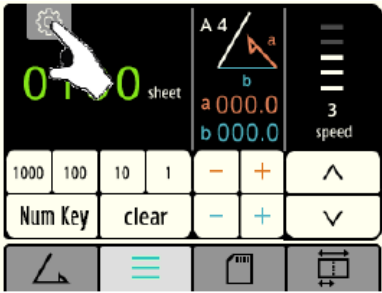
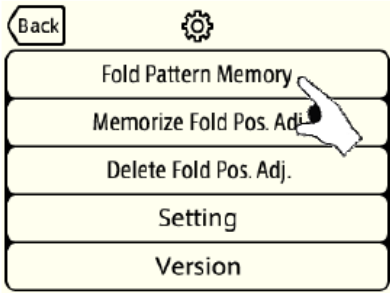
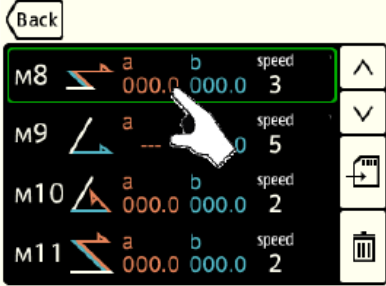
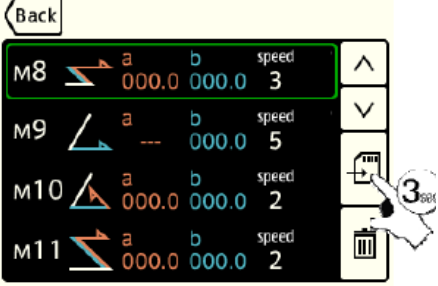
	
<p>[1]按“齒輪”鍵進入選單</p>	<p>[2] 按“Fold Pattern Memory”鍵進入記憶功能選單</p>
	
<p>[3]選擇要儲存之欄位</p>	<p>[4]按住記憶卡圖示 3 秒鐘</p>

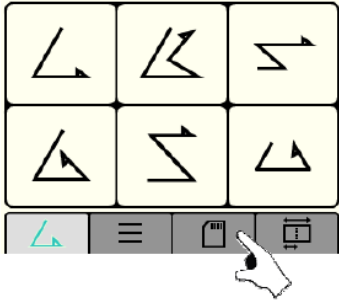
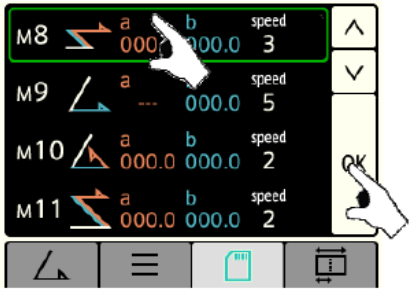
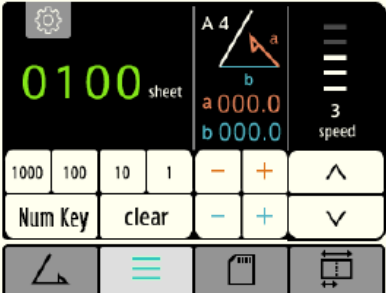
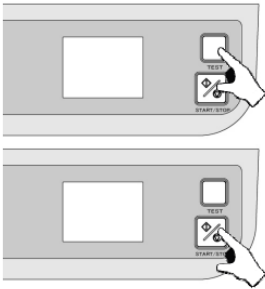

3-2 呼叫記憶功能

	
<p>[1]按記憶卡圖示進入選單</p>	<p>[2] 選擇要呼叫之欄位，並按“OK”鍵</p>
	
<p>[3]跳至主畫面，並確認各數值是否正確</p>	<p>[5]按“測試”鈕，如結果不正確，請確認輸入是否正確</p>

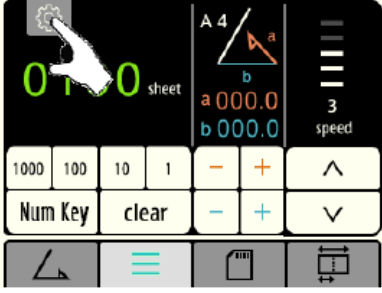
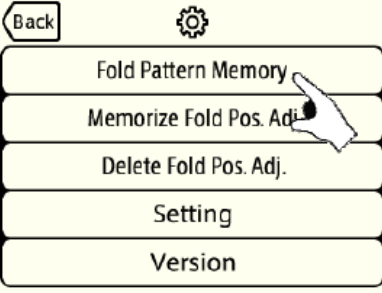
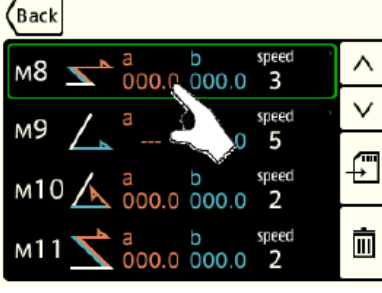
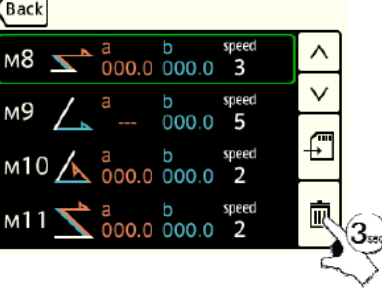

3-3 刪除記憶功能

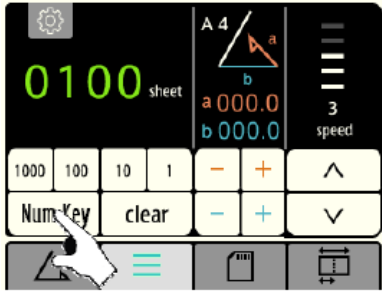
	
<p>[1]按“齒輪”鍵進入選單</p>	<p>[2] 按“Fold Pattern Memory”鍵進入記憶功能選單</p>
	
<p>[3]選擇要儲存之欄位</p>	<p>[4]按住垃圾桶圖示 3 秒鐘</p>

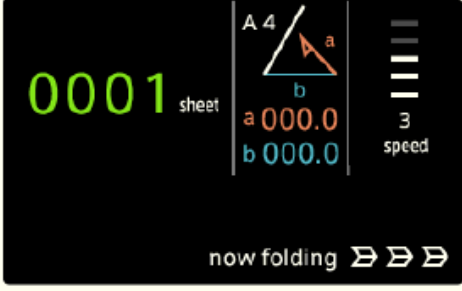
4-1 正數計數器設定

	
<p>[1]按“Num Key”鍵進入選單</p>	<p>[2] 按“clear”鍵並按“enter”鍵輸入</p>
	
<p>[3]計數器將顯示“已完成張數”</p>	

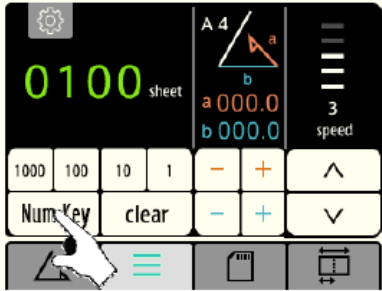
4-2 倒數計數器設定

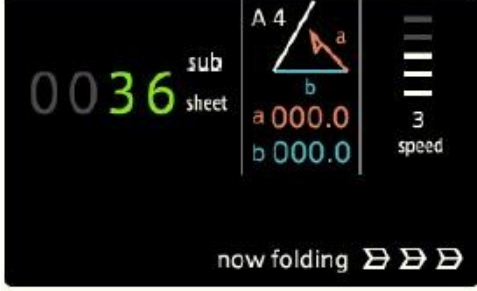
	
<p>[1]按“Num Key”鍵進入選單</p>	<p>[2] 設定張數並按“enter”鍵輸入</p>
	
<p>[3]計數器將顯示“未完成張數”</p>	

4-3 間隔啓動設定

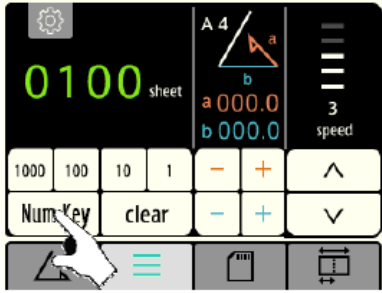
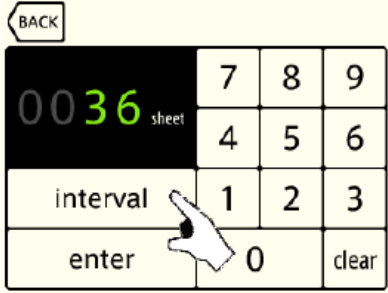
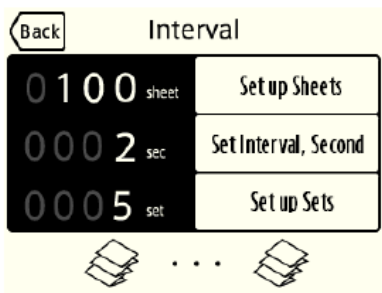
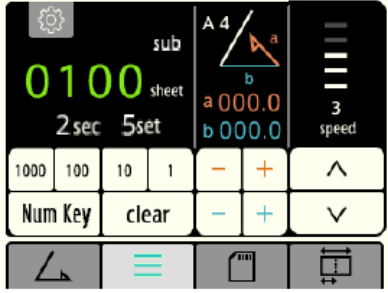
	
<p>[1]按“Num Key”鍵進入選單</p>	<p>[2] 設定張數并按“enter”鍵輸入</p>
	
<p>[3]設定張數、間隔秒數、份數</p>	<p>[4]螢幕將顯示數量、間隔秒數、份數</p>